

Baseband and RF Block diagram v.8100 ed.21

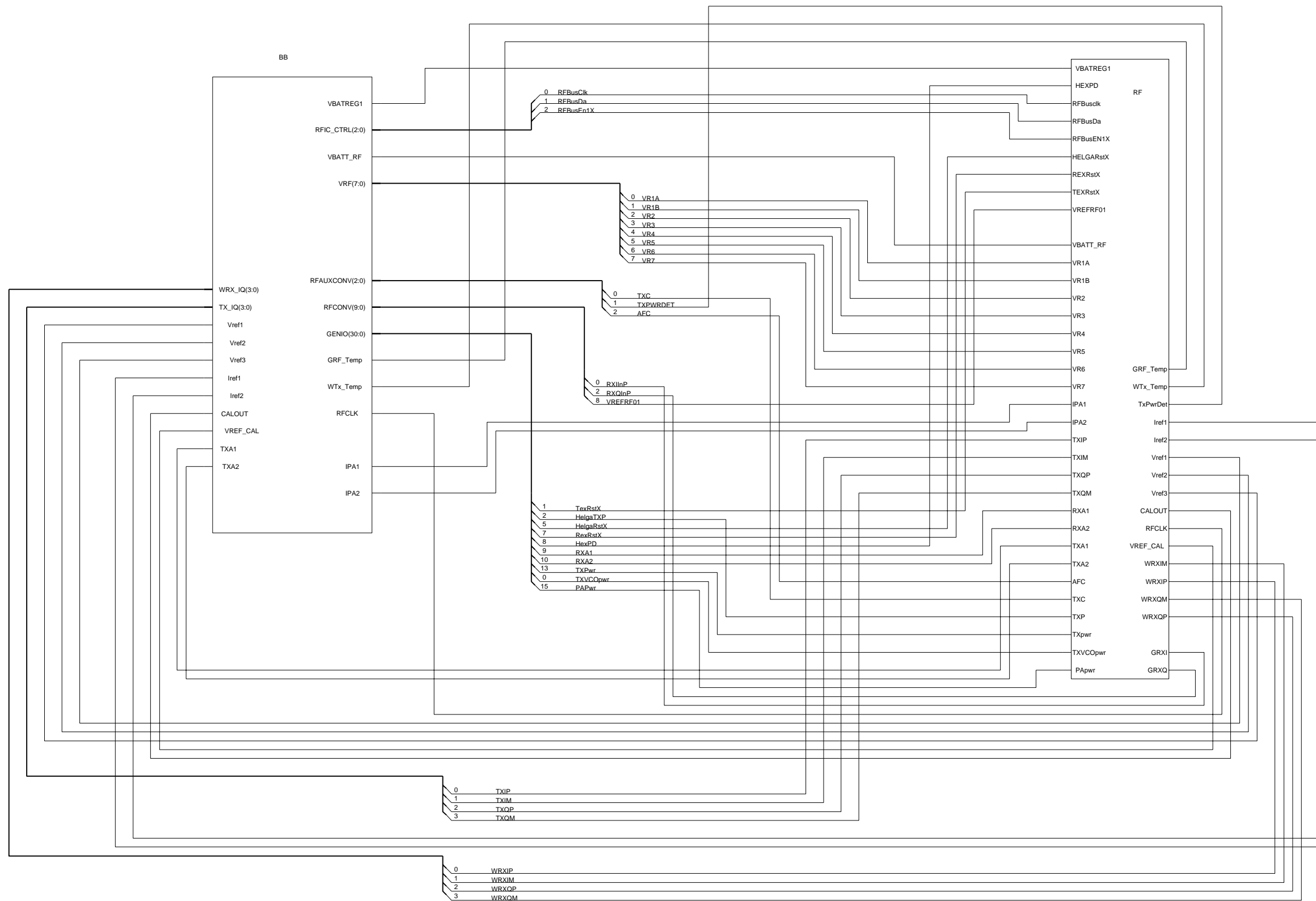

RF Block diagram v.8100 ed.18

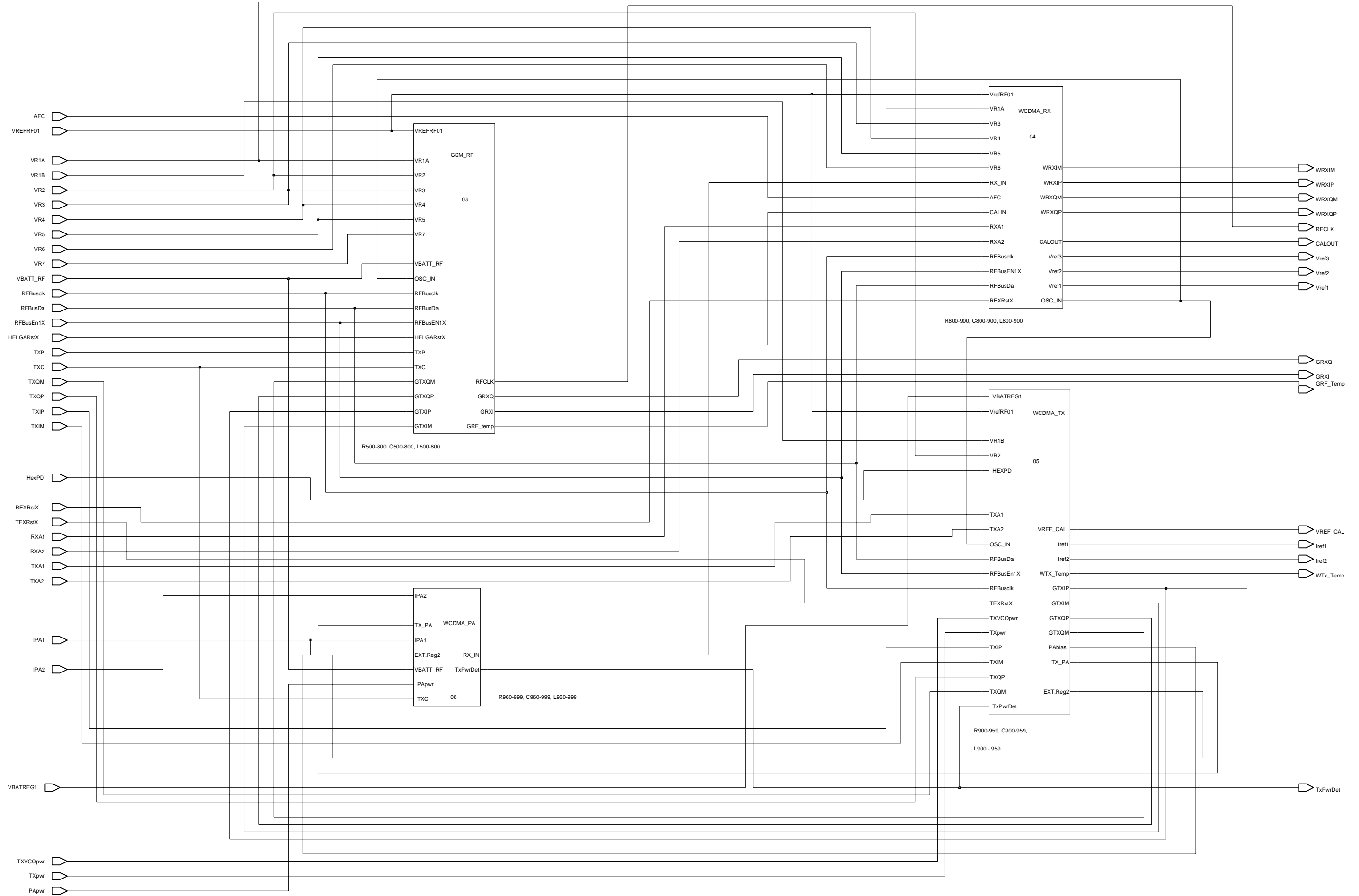

GSM RF Block diagram v.3000 ed.41

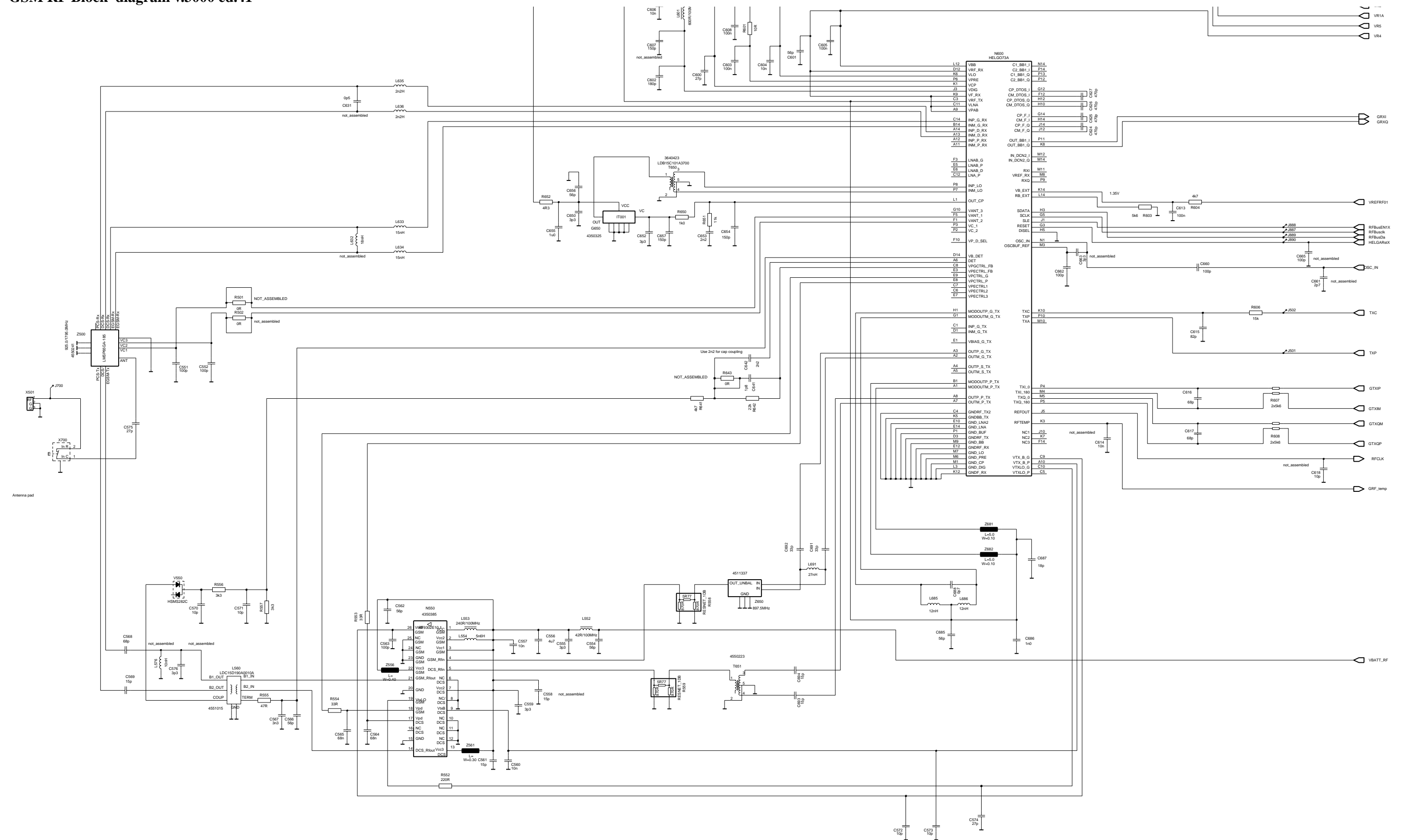

WCDMA RX Schematic diagram v.8100 ed.26

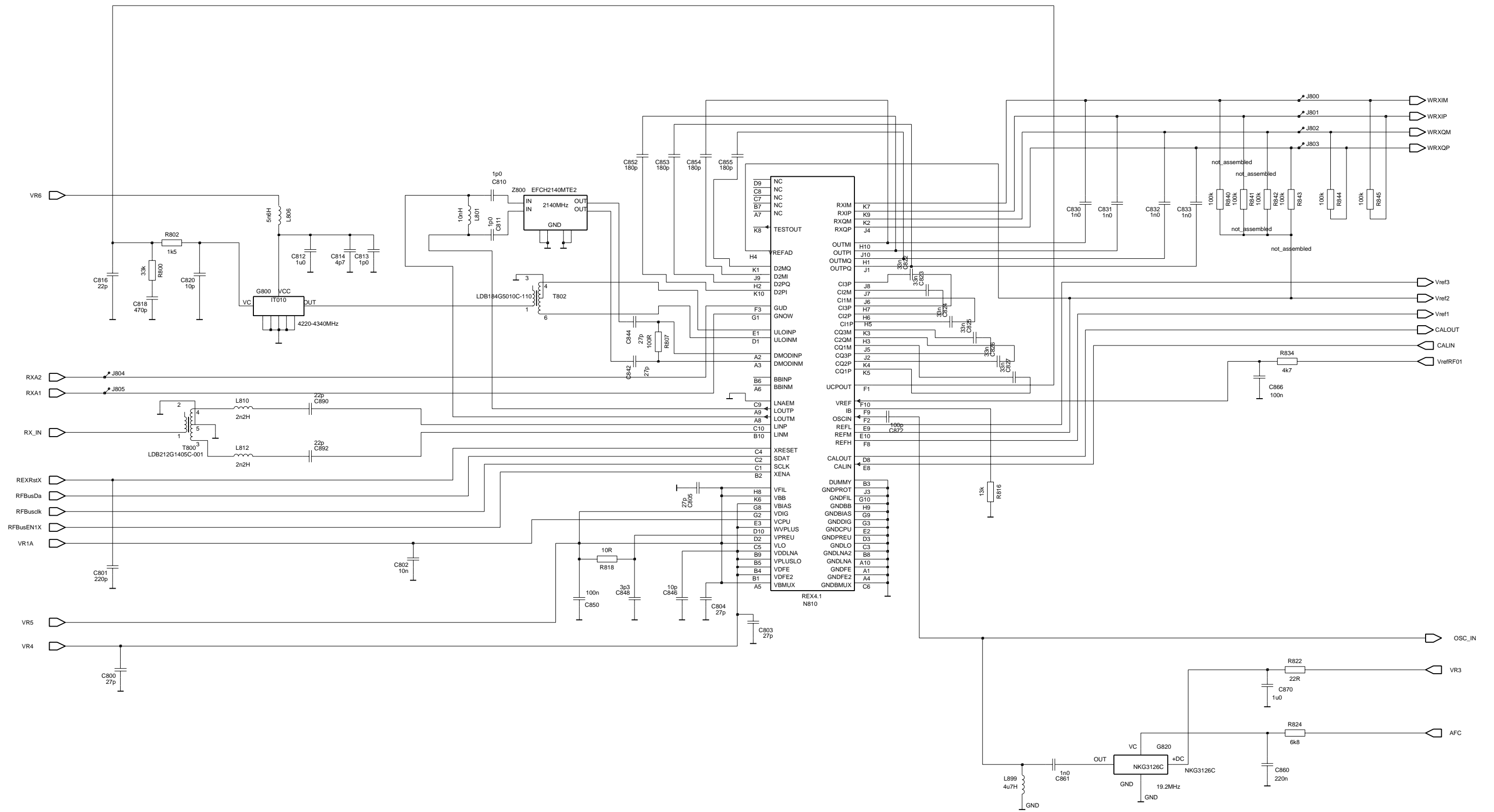

WCDMA TX Schematic diagram v.8100 ed.27

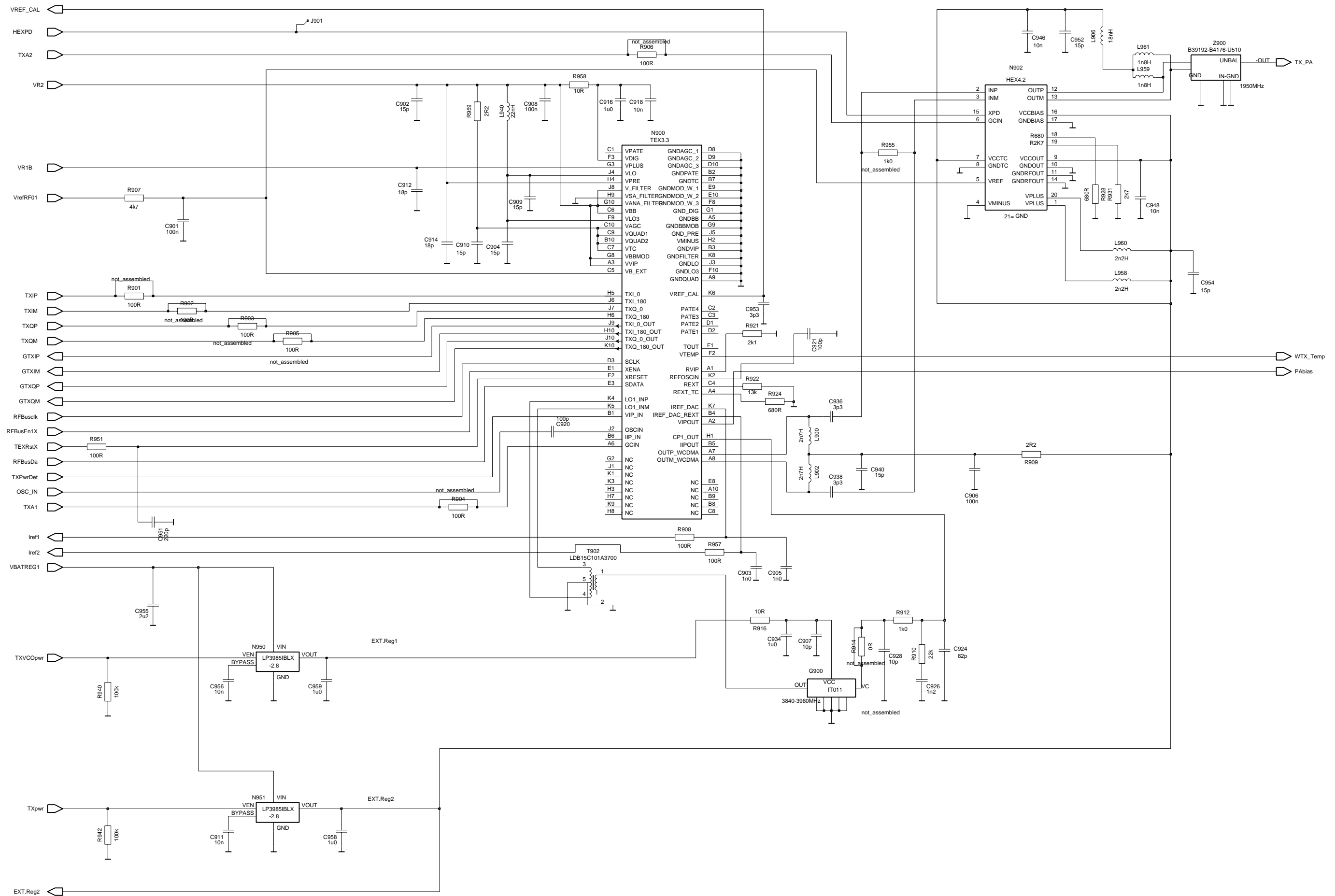

WCDMA PA Schematic diagram v.8100 ed.25

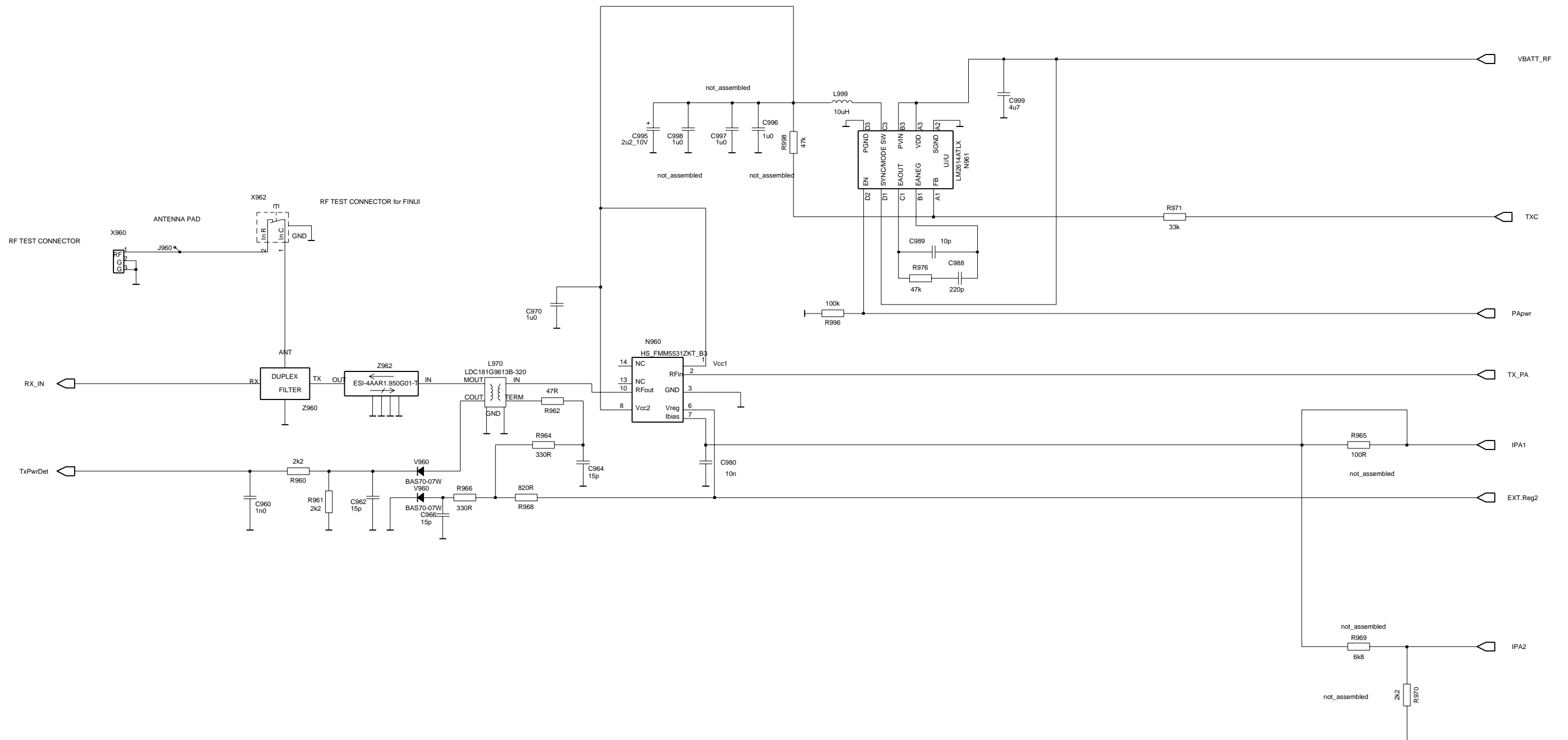

Baseband block diagram v.8100 ed.24

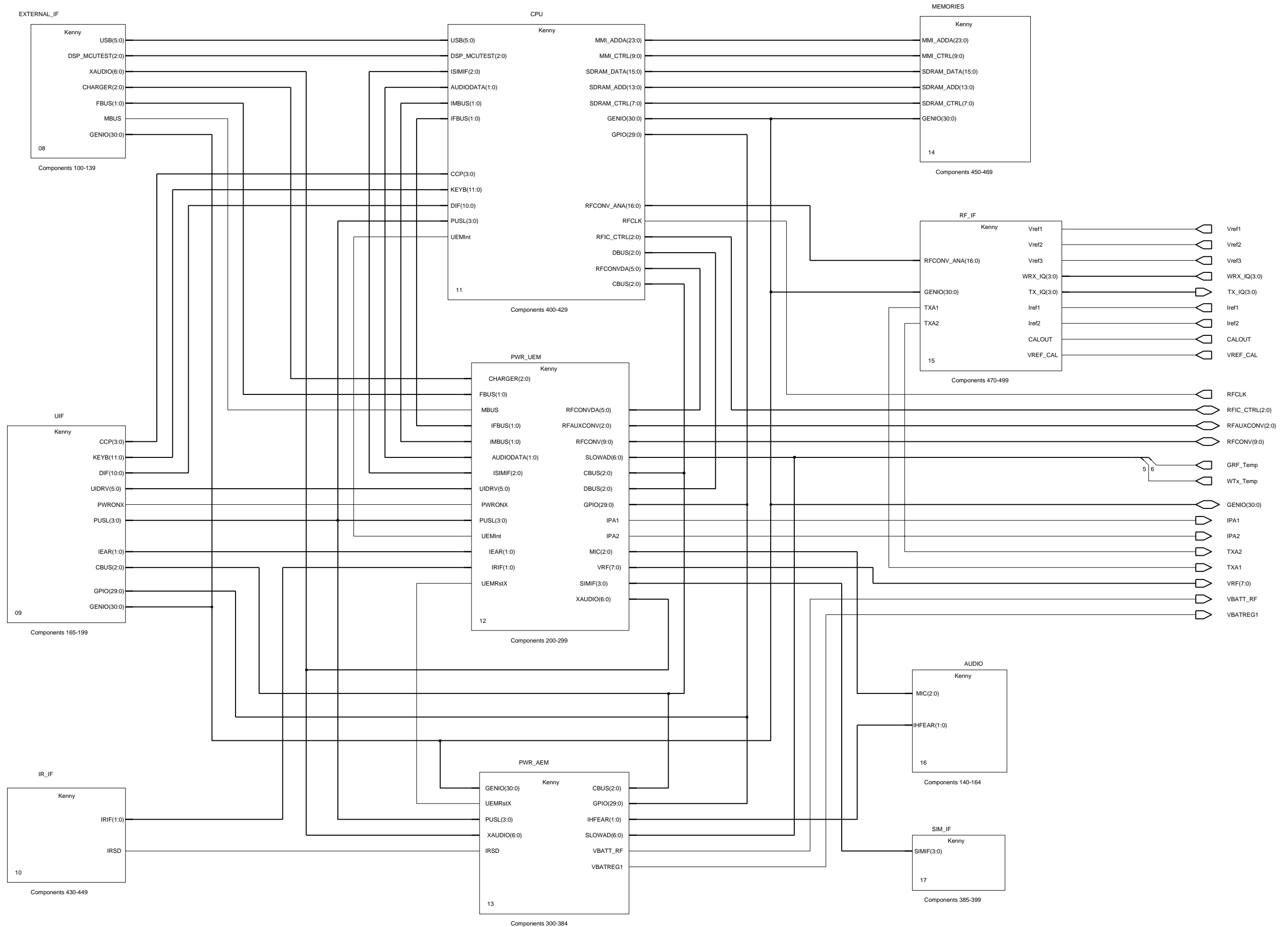

External interfaces Schematic diagram v.8100 ed.41

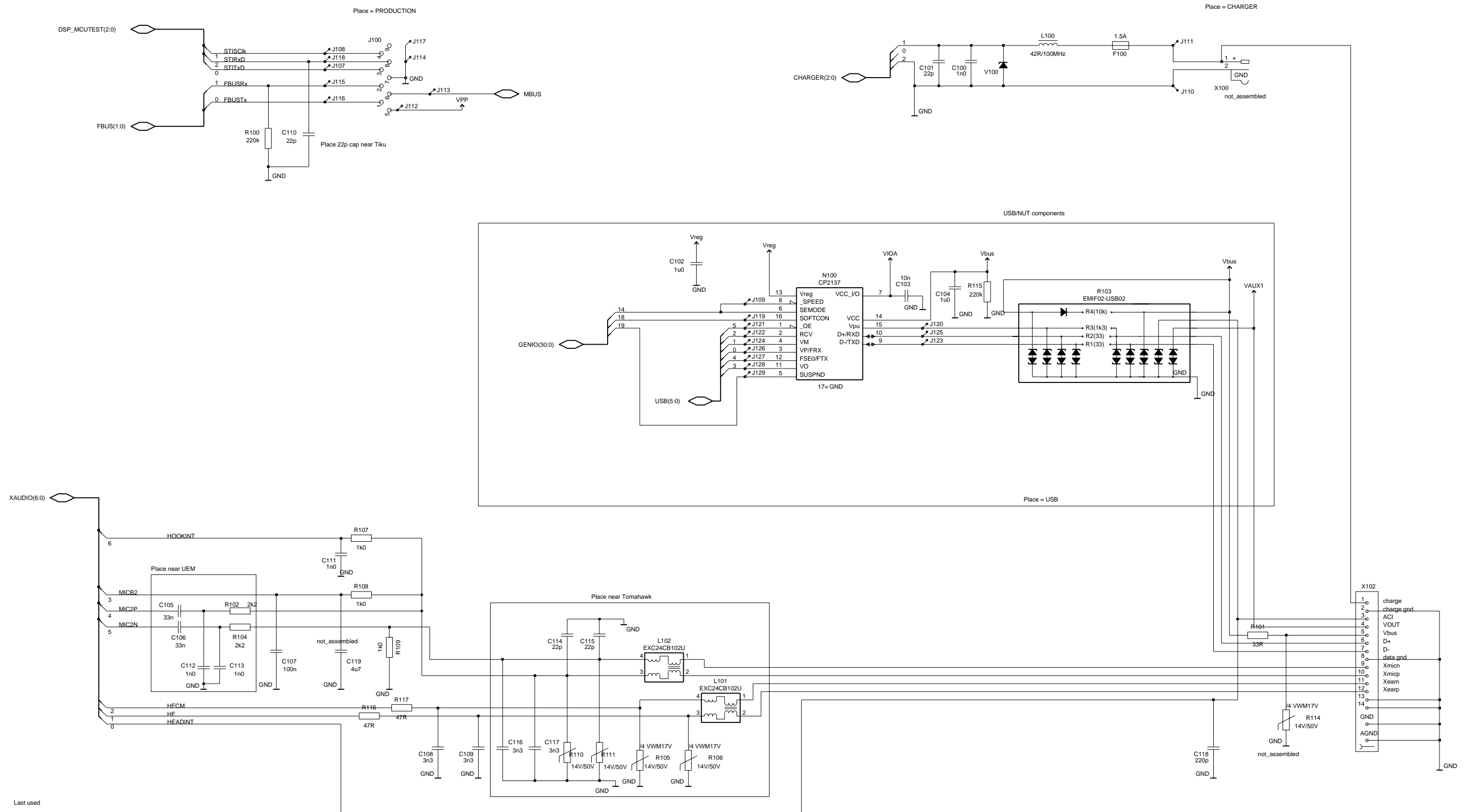

- Last used
- R117
  - C120
  - N100
  - V100
  - X102
  - J129
  - E105
  - L102
  - F100
  - D101
- D100 removed



User Interface Schematic diagram v.8100 ed.24

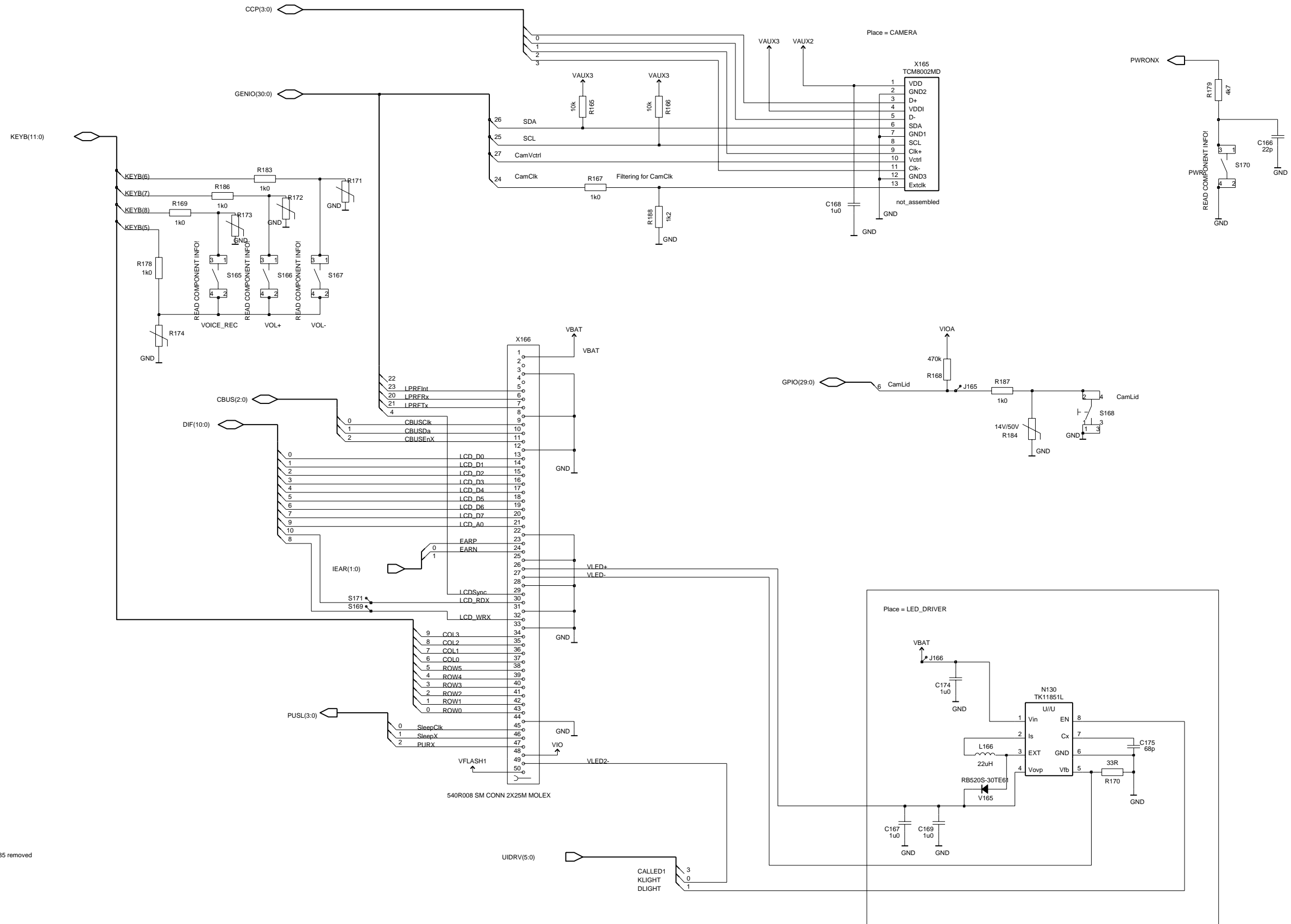

- Last used
- R188 R180, R181, R182, R185 removed
  - C175 C173 removed
  - L167 L165 removed
  - X166
  - J166
  - Z166
  - N165
  - S171
  - V165

Infrared Interface Schematic diagram v.8100 ed.19

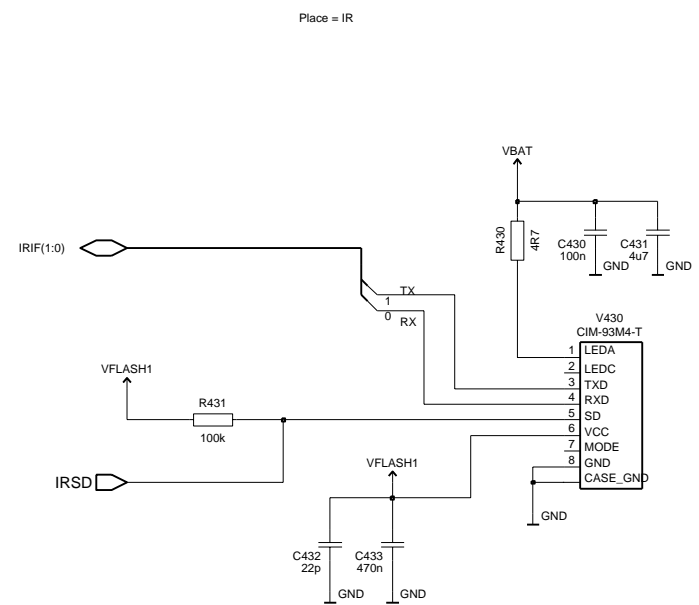

Last used

R431

C434

V430

CPU Schematic diagram v.8100 ed.27

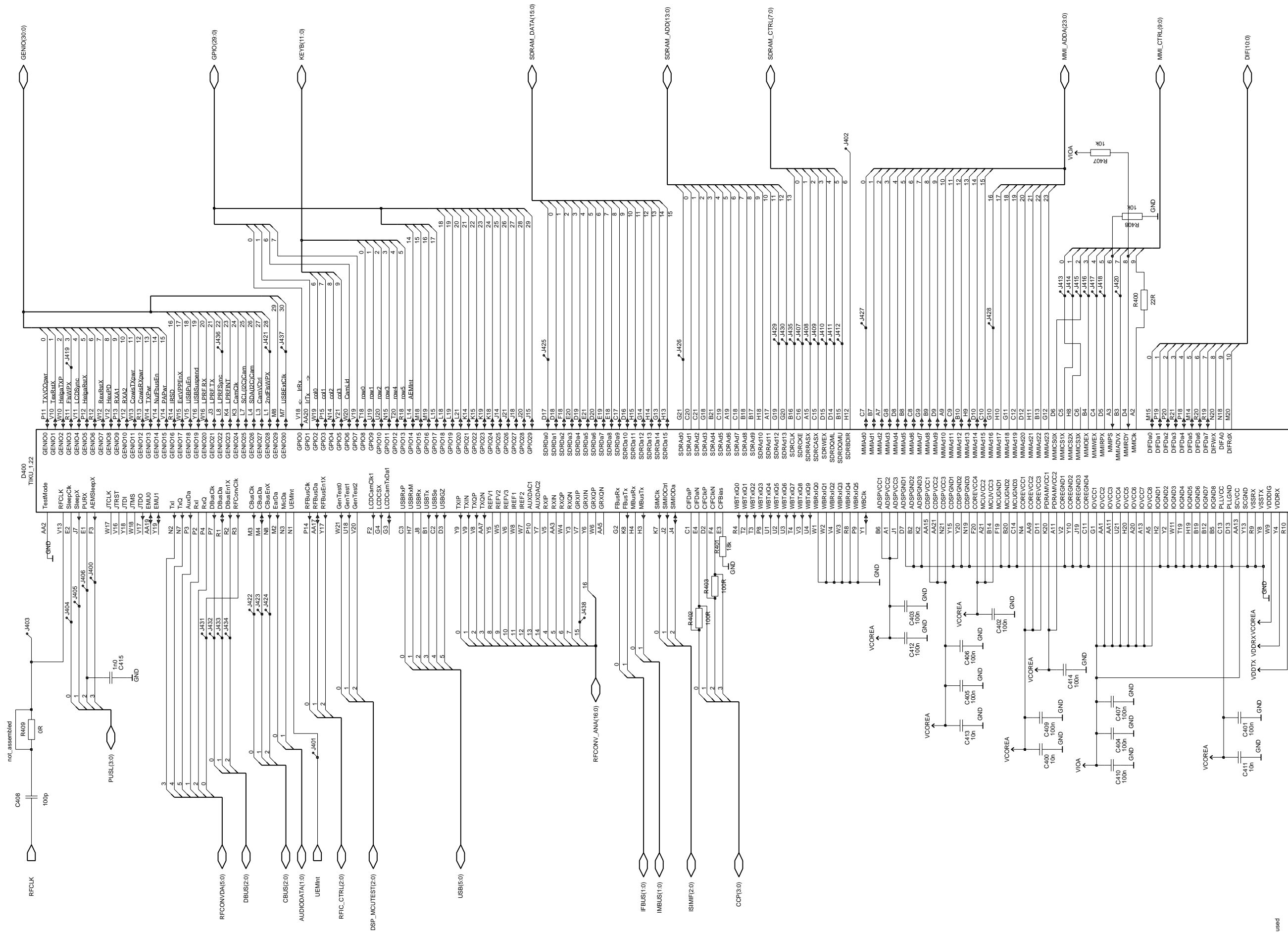

Last used  
 C415  
 D400  
 J438  
 R409  
 R404 removed  
 Place = TIKU

UEM Schematic diagram v.8100 ed.25

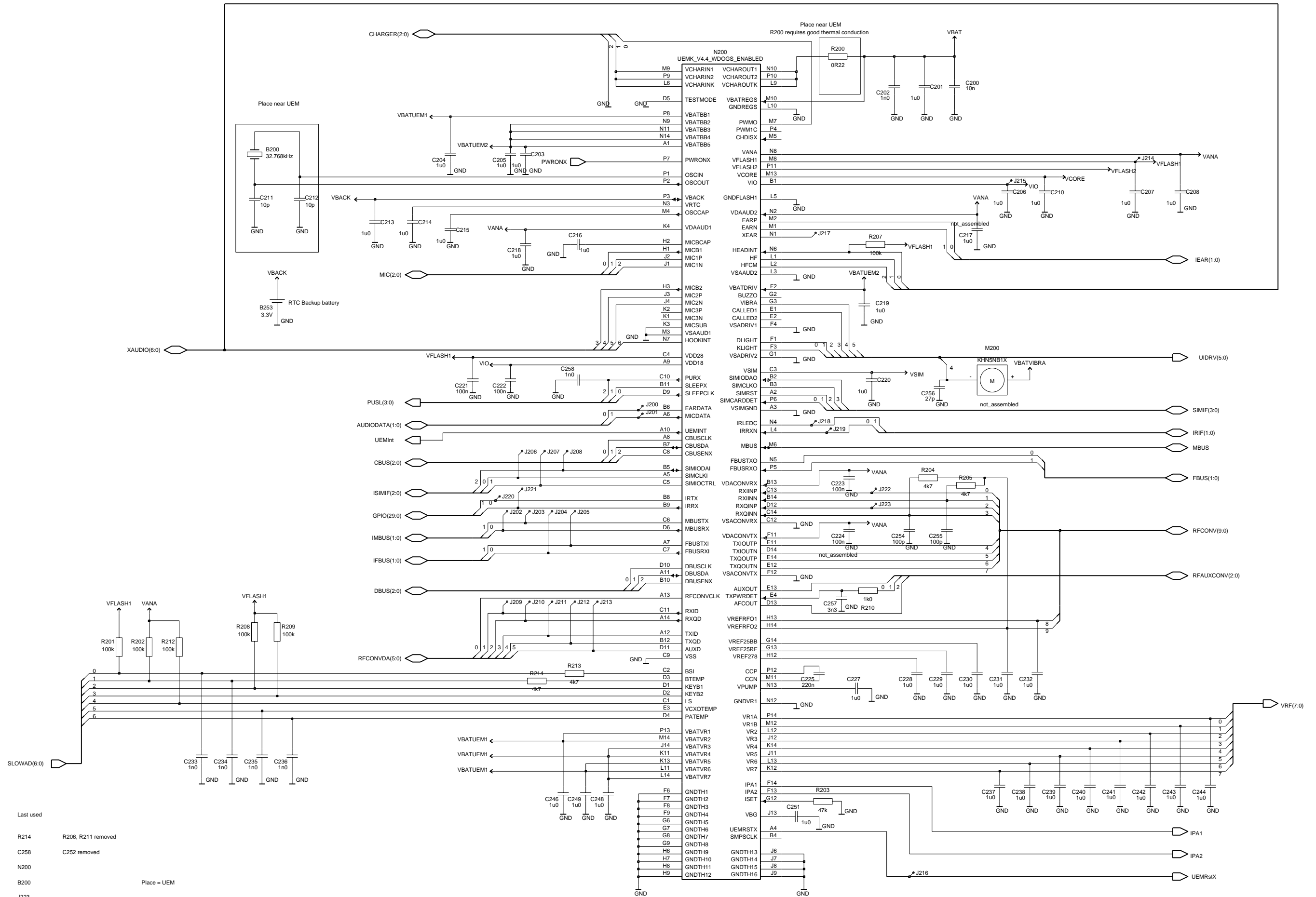

- Last used
- R214 R206, R211 removed
  - C258 C252 removed
  - N200
  - B200
  - J223
  - G200
  - M200
- Place = UEM

AEM Schematic diagram v.8100 ed.26

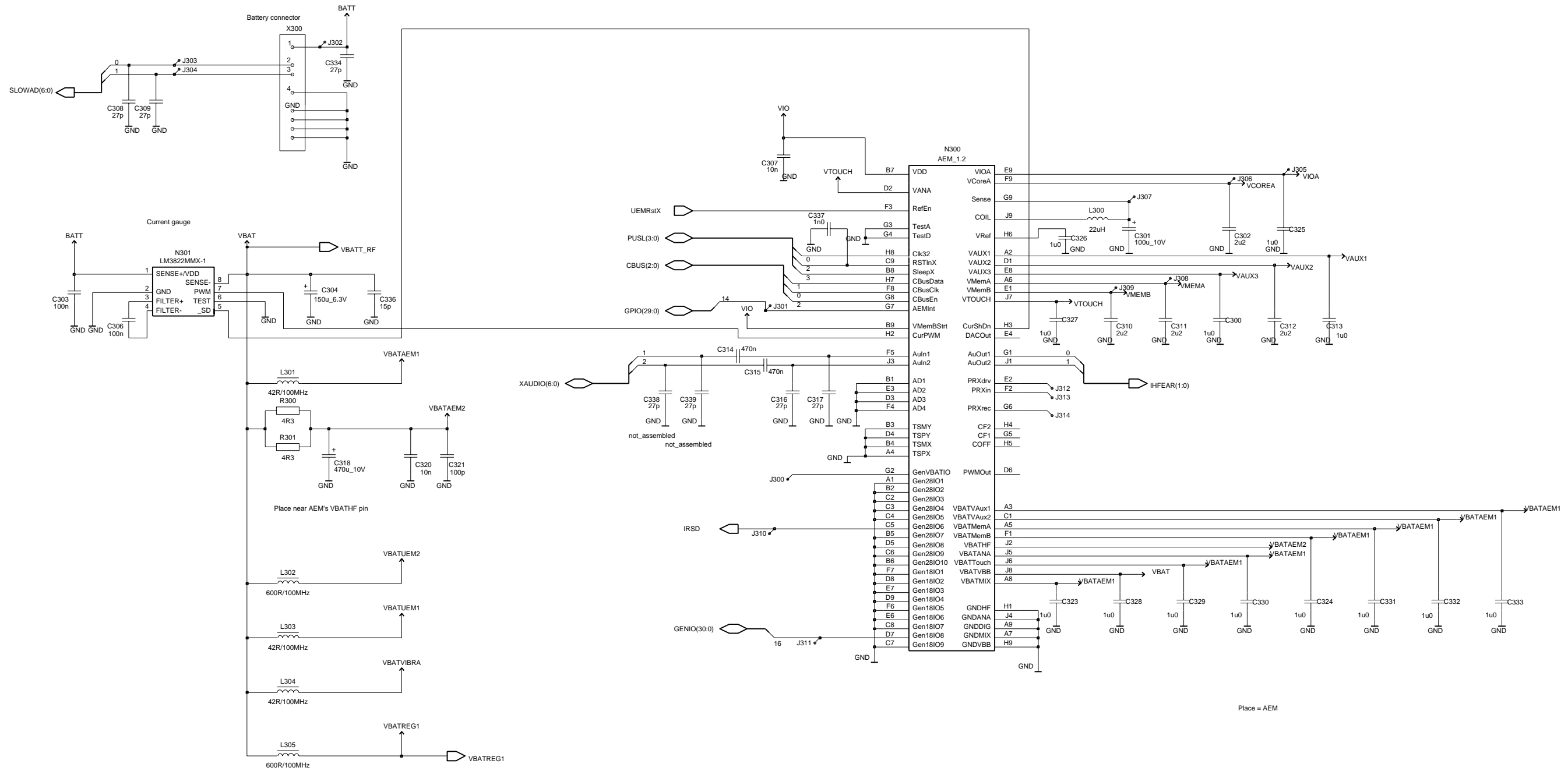

- Last used
- R305 R302, R303 Removed
  - C339
  - L305
  - N302
  - X300
  - J314

Memories Schematic diagram v.8100 ed.25

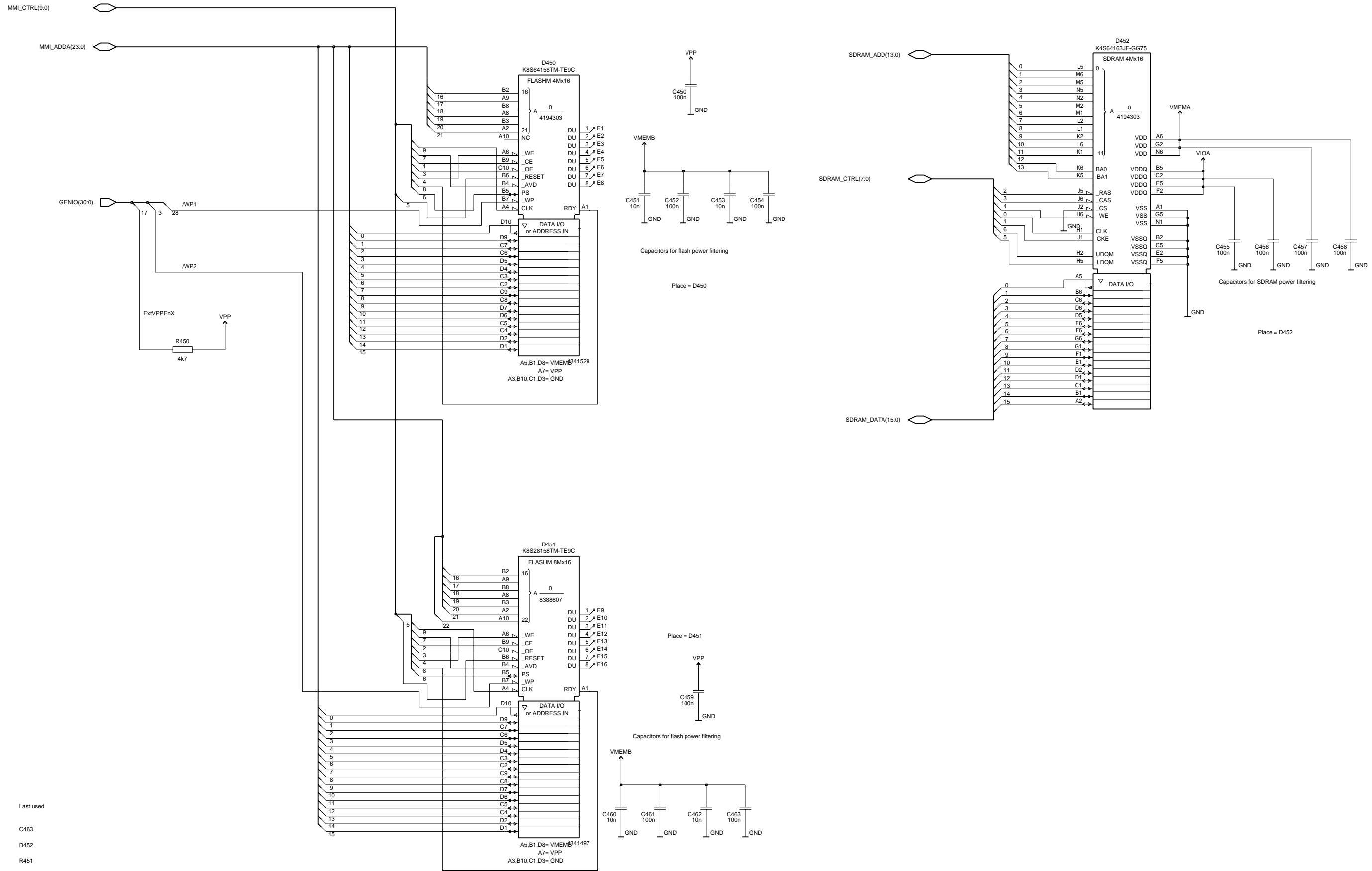

Last used  
C463  
D452  
R451  
J465

RF Interface Schematic diagram v.8100 ed.22

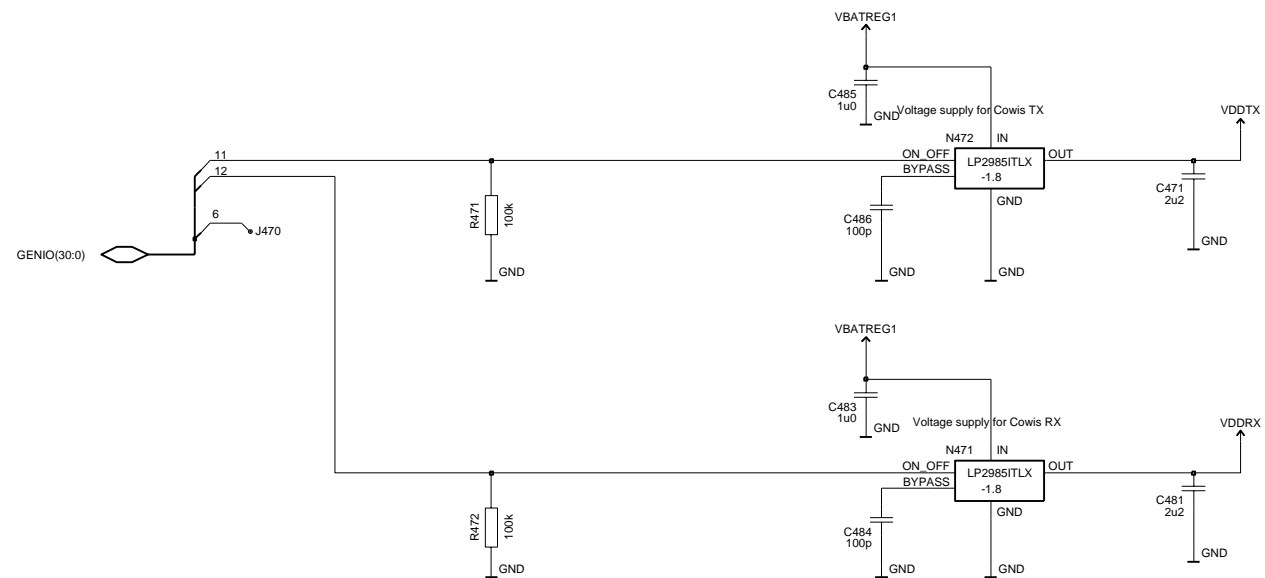
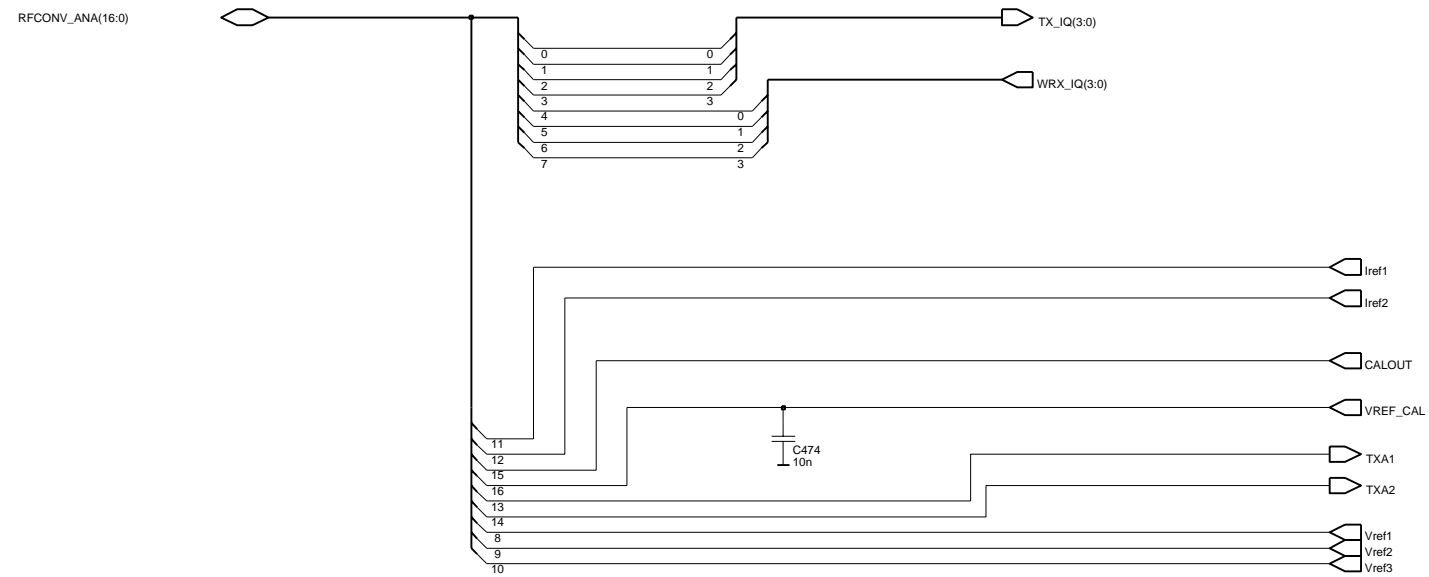

Last used

- R474 R470, R473, R474 removed
- C486 C470, C472, C473, C480, C479, C475, C476, C477, C478, C482 removed
- N470
- J470

Audio components schematic diagram v.8100 ed.21

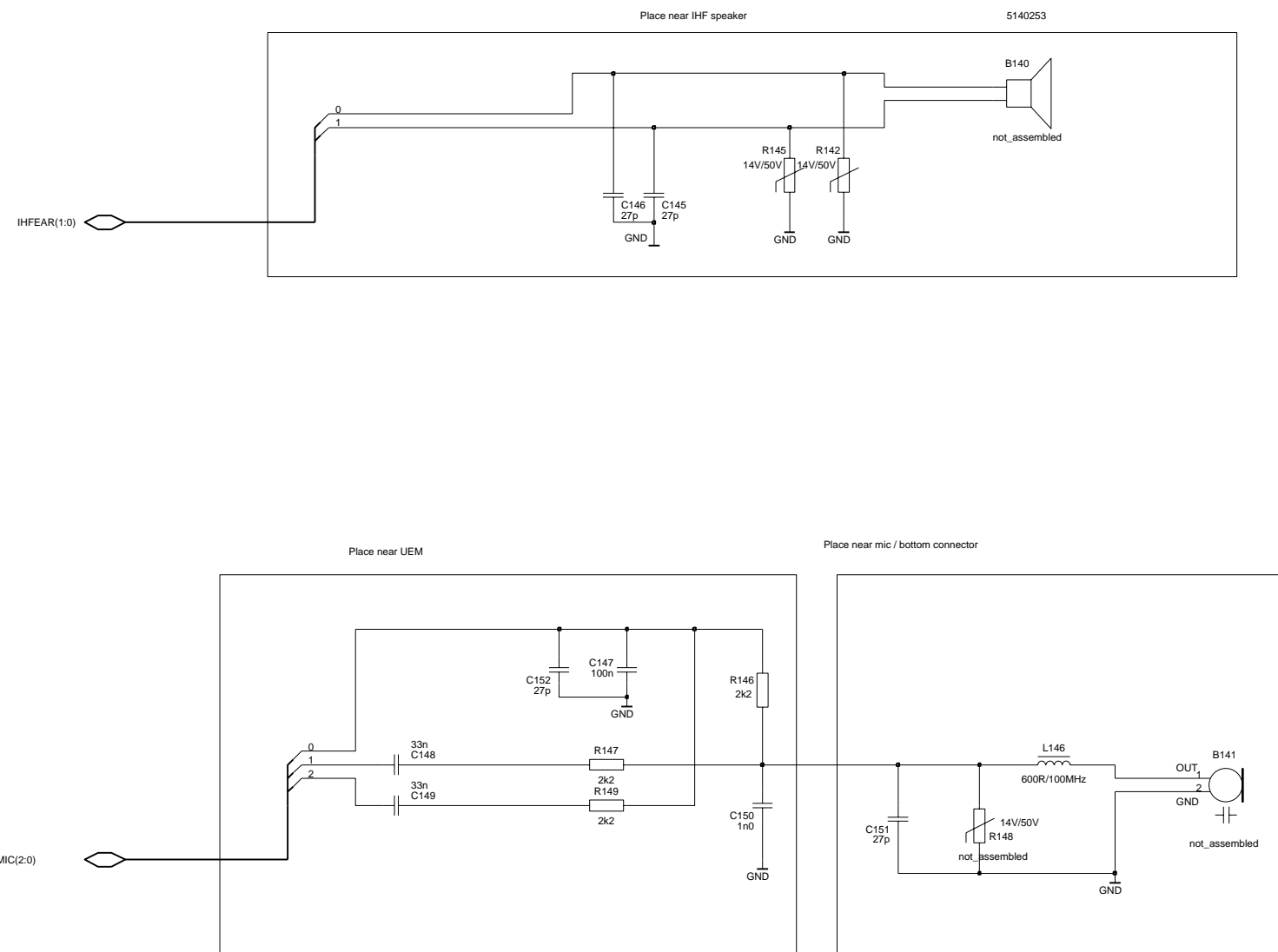

Last used

R149

C152

L147

B141



SIM schematic diagram v. 8100 ed.18

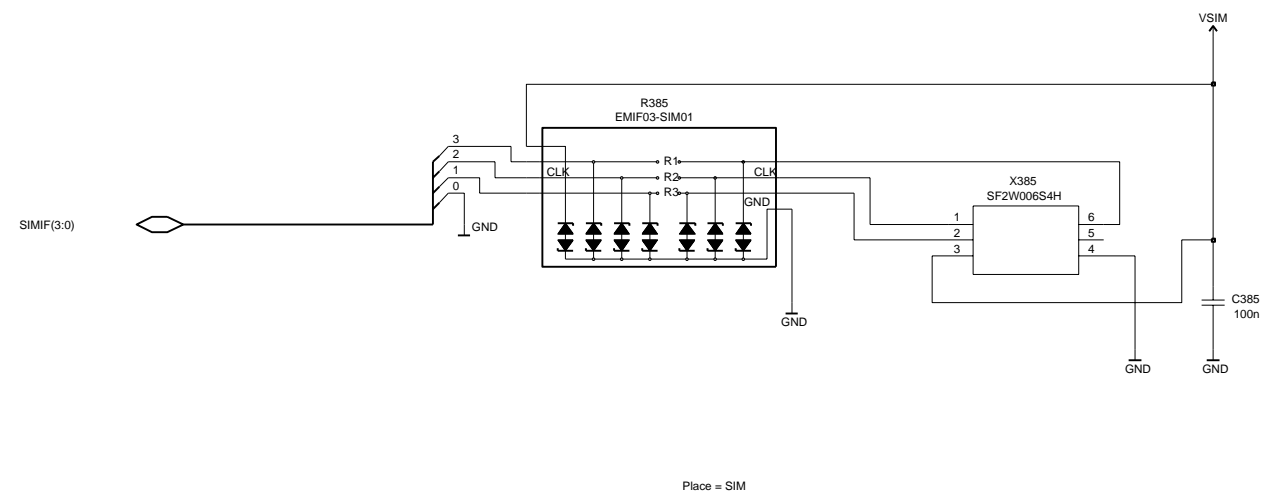

Last used

R385

C385

X385

Top level Schematic diagram v0.2 ed.9

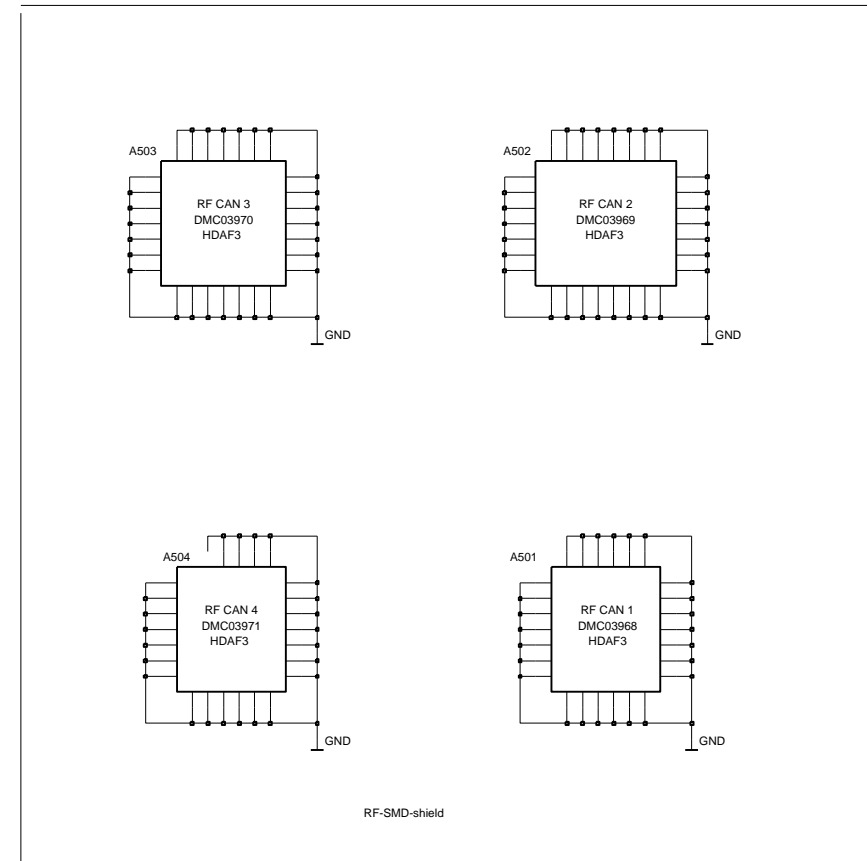
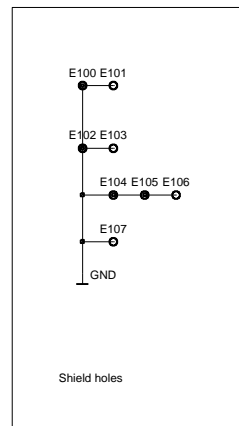

Parts placement diagram top NB8\_15A

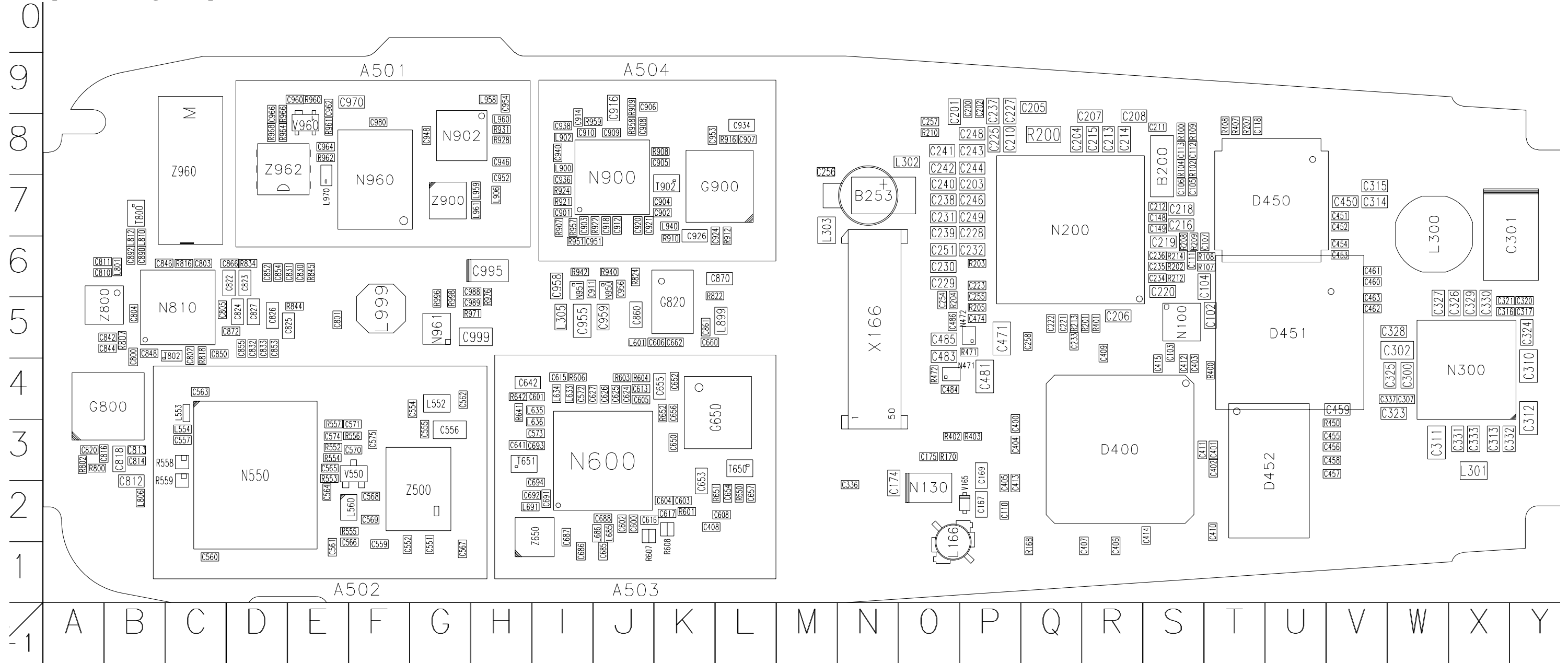

Parts placement diagram bottom NB8\_15a

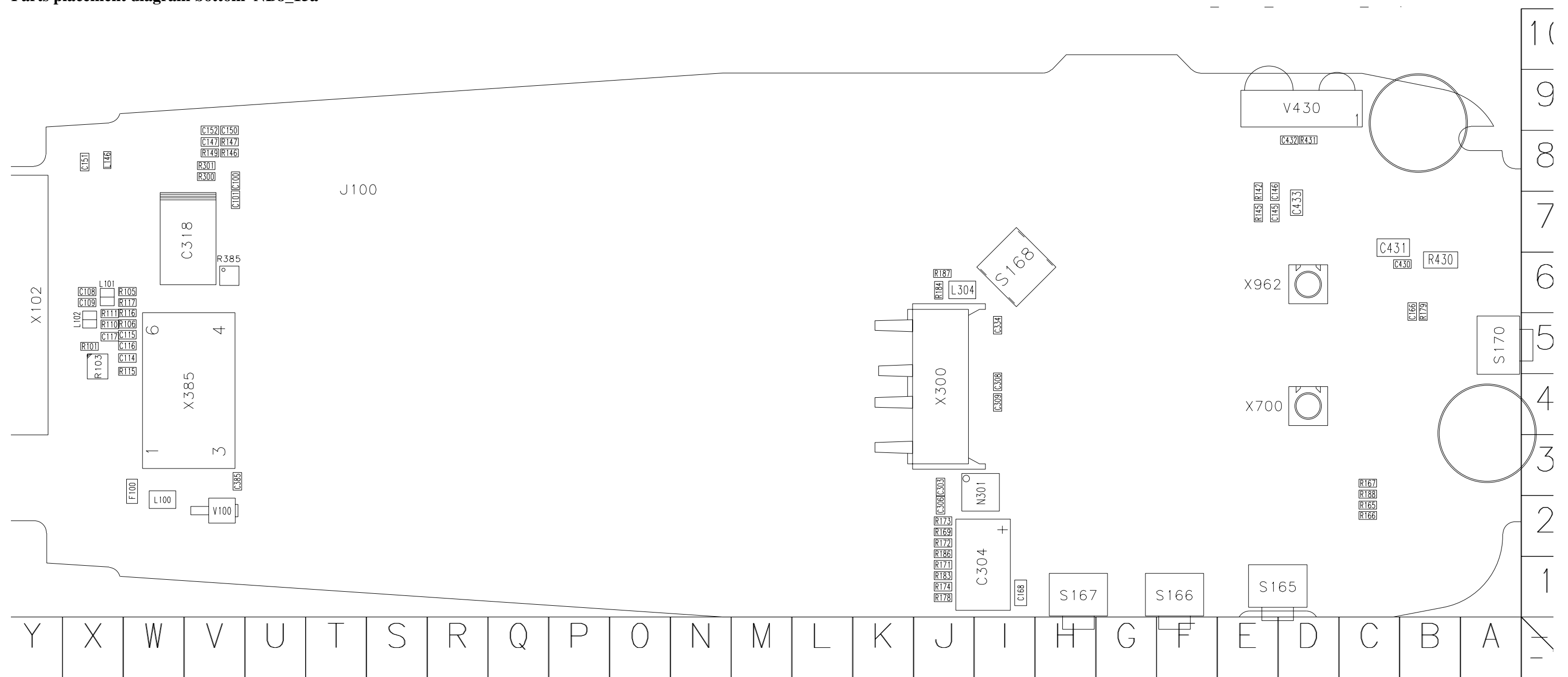

Test points, NB8\_15a top

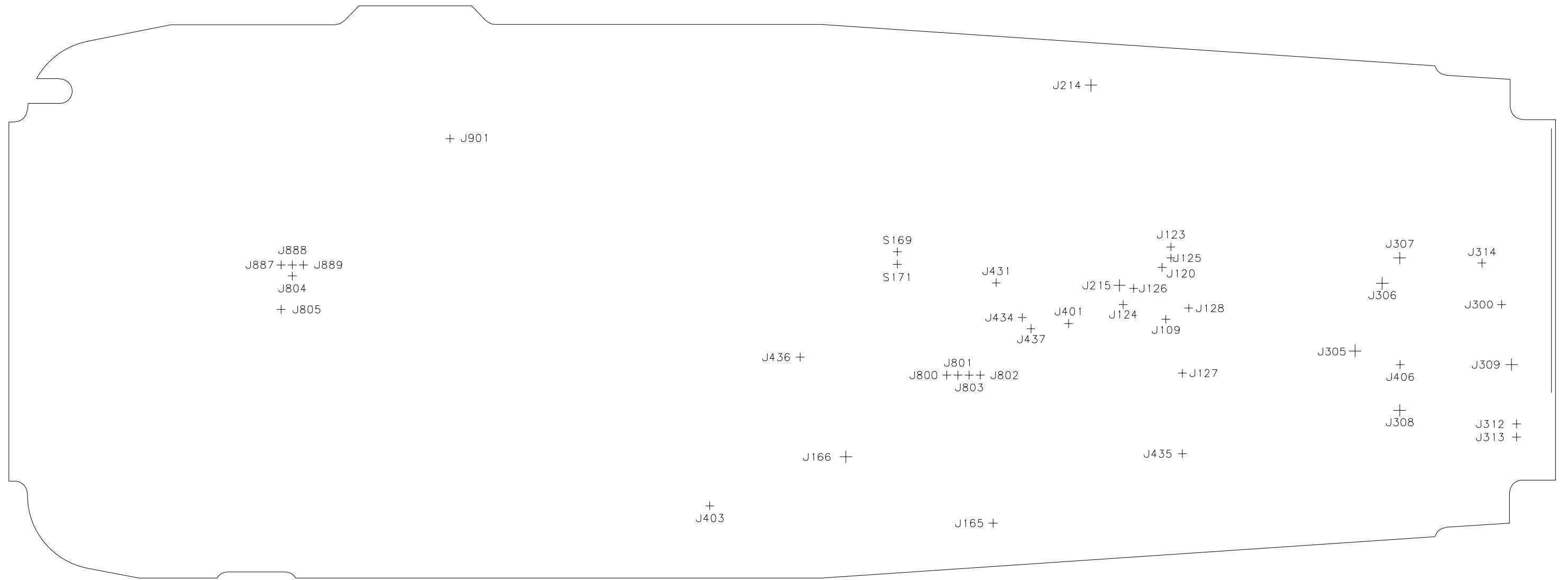

Test points, NB8\_15a bottom

